

The Fifty Ohm Enigma or, “Have you got a match?”

By: William F. Lieske, Sr. – Founder, EMR Corporation

What This Write-up Is About:

Those involved with radio frequency systems and the management of transmission and reception of various electronics messaging systems should find that this subject relates to your work. If you participate in the engineering, installation, maintenance or design of Land Mobile Wireless systems of any kind this write-up should bring to light several things that are puzzling and even mysterious: *Enigmatic*.

The *fifty ohms* reference relates to the impedance of devices such as radio receiver input stages, transmitter power input and output stages, coaxial transmission lines and antenna systems. The Ω symbol is used to represent the term “ohm,” from the Greek *Omega*, 50 Ω being the impedance value most usually found in wireless communications systems.

Background Information.

Over the many years of involvement in various types of communications systems the matter of *overall system efficiency*, has been one of the primary interests of EMR Corporation. This write-up is intended to review and explore various things that must be considered if one is to secure the highest system operating efficiencies and reliability through proper impedance matching between system elements.

Typical Transmitting Systems

Radio frequency power is most often produced by an exciter – power amplifier combination. Coaxial cable transmission line is most often used to route the signal from an exciter output to the power amplifier input and from the power amplifier to a suitable antenna in systems operating below about 2.5 GHz. Large *waveguide* is employed in microwave systems and in high power UHF TV transmission, mostly in the higher UHF channels. Systems operating above 2.5 GHz. generally employ *waveguide* to feed antennas.

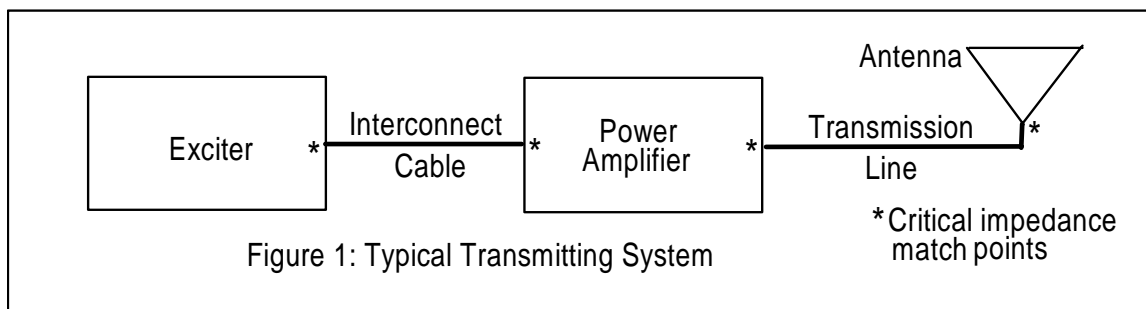

The fifty ohm enigma, or, “Have you got a match?”

The elements of a typical transmitting system are shown in block diagram form in Figure 1. The points of interest in this write-up are highlighted by an asterisk (*). Depending on the class of service that is involved, power levels from as low as a few hundred *milli-watts*, to relatively high powers, reaching many *kilo-watts*, may be present.

At each of the points noted (*) in Figure 1, an *acceptable* electrical match must exist, if high overall system efficiency is to be enjoyed. Whether the power level is milli-watts or kilo-watts, any loss of electrical energy is costly. At low power levels poor efficiency results in lower signal power actually transmitted, costing reduced communications ranges. At higher powers, losses increase the cost of electrical energy needed to generate power. All elements of the transmission system are also placed at risk due to excessive heating of critical system elements as well communications range reductions particularly in high or continuous duty operation.

Where Losses Occur In Transmitting Systems

The simple answer is: *Anything that conducts power* will contribute to circuit losses, particularly, if the *dynamic impedances* of all elements are not matched to each other. Cables conduct power and, therefore, contribute to losses. In the wireless industry the standard impedance characteristic of systems has been 50 Ω for at least fifty years. Accordingly, all devices and cables must exhibit this impedance for highest overall system efficiency. To complement these cables 50 Ω connectors must be employed.

Please note that the “UHF” connector series, including PL259 and SO239 types, still found in use, were devised more than fifty years ago when 50 MHz. was considered the “top” of the radio spectrum. They are not constant impedance devices and can produce rather severe mis-matches in critical systems at frequencies above 30 MHz..

A Close Look At Coaxial Cables

Coaxial cables consist of a tubular or braided “outer conductor” with a concentric solid or stranded “inner conductor.” The inner to outer conductor aspect ratios along with the nature of cable’s dielectric insulation material will determine the characteristic or “surge impedance” of a coaxial cable.

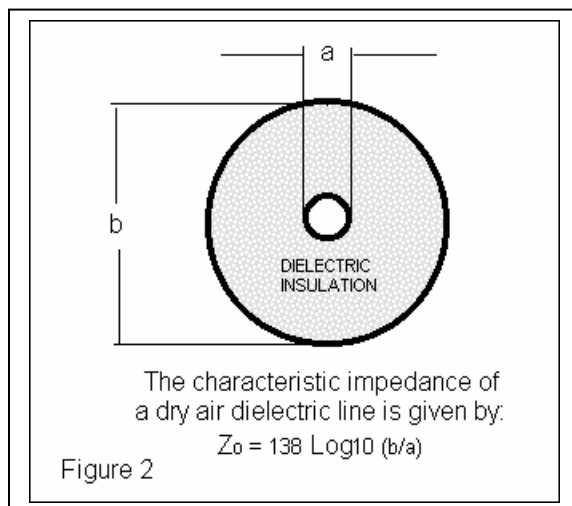

As suggested in Figure 2 the impedance of a dry air dielectric transmission line is given by the formula:

$$Z_0 = 138 \log_{10} (b/a)$$

Where:

Z_0 = Characteristic Impedance in Ω

b = Inside dia of outer conductor

a = Outside dia. of inner conductor

(Note: All dimensions must be in same units of measurement, eg: Inches, mm, etc.)

The fifty ohm enigma, or, “Have you got a match?”

Dielectric Properties

The term “*Dielectric*” applies to any material that is a *non-conductor of electricity: an insulator*. Dry air at sea level has the dielectric value of 1, all other insulating media having a dielectric value larger than 1. Cables using solid vinyl or foam dielectric, solid or spiral ribbed Teflon® insulating spacers as found in current cable designs, can have dielectric constants up to several times higher than that of dry air at sea level. Dry nitrogen, an inert gas filtered through a “desiccant” to remove all moisture, held at somewhat higher than sea level air pressure is widely used in sealed solid cables to insure that atmospheric changes and relative humidity will not result in changing cable impedance due to air moisture content and/or atmospheric pressures..

Where high power handling and higher frequency operations are involved larger diameter cables are used, having lower losses per given lengths. Cable loss is usually rated in dB (decibels) per 100 feet in popular land mobile frequency bands. The longtime standard RG-58 and RG-8 flexible cables have now been replaced in most, if not all, commercial grade systems with double shielded, silver plated conductors and Teflon® or special types of foam dielectric types to yield lower losses and much improved cable to cable shielding. Semi-flexible solid conductor cables, or rigid, solid conductor cables use ceramic insulators or spiral Teflon® inner conductor centering supports along with dry nitrogen pressurization to provide low losses. Such cable types find application in higher power and higher frequency applications.

Most CATV and CCTV distribution systems were standardized at 72 Ω impedance many years ago and that system impedance continues to be used at the present time in that industry. Where special system requirements arise, such as in the use of cables as *linear transformers*, we find cables having 75, 93 Ω and other special impedances. These types are available from several cable manufacturers. Cable network designers use specific lengths of such cables match sections impedances between otherwise mismatched devices or circuits.

The Realism of Impedance Matching.

It has often been suggested that where all elements of a system are 50 ohms, one can use *any length* of 50 Ω cable and a “perfect match” will result. *This can only be true where all of the system elements have a purely resistive 50 Ω characteristic, exhibiting no inductive or capacitive reactance.*

Read the preceding paragraph again, PLEASE!

In the practical applications of radio frequency devices, the presence of even relatively small inductive or capacitive effects can result in reduced overall efficiency where two or more devices are connected together with cables. The reactive components must be accounted for through suitable cable matching if the best possible performance is to be enjoyed. To fully understand the implication of this we will look into the nature of amplifiers before addressing the matter of impedances of transmission lines and antennas.

The fifty ohm enigma, or, “Have you got a match?”

The Anatomy of Exciters

Most modern frequency generation is accomplished through electronic synthesis. The flexibility and ease with which today’s multi-channel transmitters and receivers are programmed and operated is made possible through modern “solid state” synthesizer technology.

Design considerations of synthesizers is a subject unto itself. The modern *solid state* exciter will produce highly stable channel frequencies as programmed, at a low power level using complex frequency synthesis to develop the precise channel frequencies desired. Modulation is usually applied to the selected carrier as a part of the synthesizer functions. Successive stages amplify this signal to a power level suitable to drive a power amplifier (P. A.). The P. A. may have two or more stages as needed to develop the desired system power output level.

Within the exciter, various inter-stage impedances are found as determined to suit the designer’s choice and availability of active circuit components. It is usual practice to design an exciter’s output impedance to be 50 Ω at some given power level such as 3, 5 or 10 watts, where various makes or types of P. A.’s are likely to be used, with the assumption that the amplifier’s *input* impedance will present the same impedance as the “load” for the exciter’s output. It is important to assure that a proper impedance match exists since the exciter is really a low power transmitter. It will deliver power to the P. A. input most efficiently and cleanly only when its output impedance is matched to the P. A. input impedance.

It is not uncommon to find situations in which an exciter that can deliver clean, desired, drive power to a P. A. becomes erratic and will develop spurious output frequencies or fail when the P. A. input impedance is significantly different than fifty ohms, *or that a mismatched cable was used* between the exciter’s output and the P. A. input. Where an exciter is rated for, say, 5 watts of power output and uses a Class “B” or “C” output stage along with an “output level” adjustment in some prior stage of the exciter it is often found that the *effective* impedance can vary widely as the exciter’s output power is varied through its available adjustable power range.

This fact is often overlooked by many technicians, under the mistaken assumption that the exciter’s output impedance is constant, regardless of the power being produced.

Typical Solid State Amplifiers.

For many years, solid state amplifier designs were based solely on *power transistor* technology, however, the industry is now moving toward *Power FET* amplifying devices. We can expect, however, to see amplifiers using bi-polar power transistors for several more years since most of these component devices were designed to operate directly from 12.6 V. D. C. (nominal) vehicular power sources, whereas, power FET’s classed at 25 watts or above usually require higher operating voltages, complicating power supply requirements, particularly in vehicular applications.

R. F. Power transistors are found to include devices producing from under 1 watt to sixty watts or more and power FETs are now available for up to the 250 watt output class. It is traditional in transistor P. A. designs to use a single stage with sufficient power

The fifty ohm enigma, or, “Have you got a match?”

gain to drive two or four “push-pull, parallel” devices fed by hybrid splitters to their inputs and re-combining the outputs using hybrid devices.

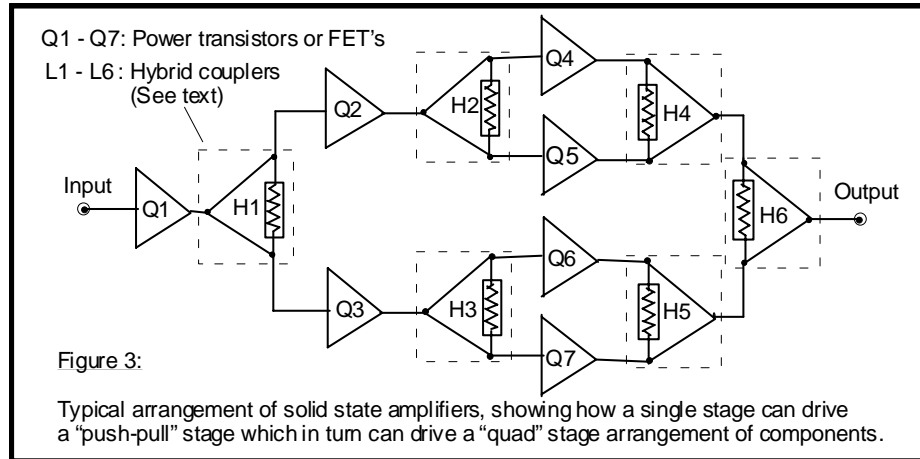

Figure 3 shows, in block diagram form, the typical arrangement of components in solid state amplifiers. In these circuits, the active devices are usually operated in a Class “B” mode, drawing a very small amounts of current until excited by a *driving* signal. Since their dynamic operation is determined by *drive level*, the greater the amount of drive power, the greater will be the D. C. current drawn from the power source.

The Hybrid Couplers can be of the 90° type, or as shown in Figure 3, a “Wilkinson” design, using strip-line elements in typical designs. Two half wavelength 70Ω lines provide 50Ω source and output impedances over reasonable bandwidths. The load terminations are 100Ω resistors, usually mounted on a *heat sink* that also serves to dissipate heat developed by the active devices. The resistors dissipate little or no power as long as the energy at their opposing ends are 180° out of phase and equal in voltage amplitude as long as circuit balance is maintained.

The dynamic impedance at both the input and output of these stage(s) will change as applied driving power changes. In a properly designed amplifier of this type there can be only a relatively narrow range of output level in which a particular dynamic operating impedance exists. Amplifier designers strive to meet the component manufacturer’s recommended operating levels using suitably selected circuit constants to arrive at target input and output impedances.

Thus, *Class “B”* and *Class “C”* amplifier designs must be designed to meet a particular target output power level, and can be expected to perform at their highest efficiently within a relatively narrow range of power output levels. *It is important to be cognizant of the fact that operating a given amplifier at levels above or below its designed power output rating will result in variations in its dynamic input and output impedances.*

Power FET amplifiers are sensitive to the same considerations. Their input impedance is much higher than transistors and correct input matching is more critical if stable, low intermodulation performance is to result. If *any* amplifier is significantly over-driven, device failure will often result unless some form of protective circuitry has been provided to limit input drive level relative to output power level. Over-excitation will result in excessive current being drawn by the transistors or FETs, causing component

The fifty ohm enigma, or, “Have you got a match?”

failures and/or damage to circuit boards or other components due to the generation of excessive heat.

Most power transistors employ multiple junctions on a single substrate. Partial component failure such as the failure of some of the internal junctions in a power transistor in a “single-ended” stage can lead to erratic operation and/or spurious signal generation. In the case of a multiple transistor stage the failure of one device will result in severe circuit unbalance, generally leading to total failure of the remaining device(s) and/or the generation of unwanted, spurious signals before complete failure occurs.

The forgoing discussions were intended to review how the dynamic working impedances of *any Class “B” or Class “C” amplifier* are influenced by the level of applied input signals. In the case of pure Class “A” and certain Class “AB” types of amplifiers the impedances of related devices can be less critical, from a practical standpoint. For example, in audio power amplifiers, impedance matching between the amplifiers and the loudspeaker systems is a necessary but is generally more tolerant of mismatch because the Class “A” audio amplifier’s output impedance is generally corrected through the use of inverse feed-back loops, which tend to compensate for and *cover up* mismatches.

Cable Velocity Factor Considerations

The *velocity factor* of a cable relates to the rate of signal propagation through the cable referenced to the rate of electro-magnetic wave propagation through space. Typical velocity factors vary from about 65% to as high as 97% of free space propagation, depending on the materials used for the conductors and the characteristics of the dielectric material employed. The formula below defines velocity factor:

$$VF = \frac{\lambda}{(983.6 / f)}$$

Where: VF = velocity factor.

λ = free space wavelength in feet

f = frequency in MHz.

The velocity factor of popularly used flexible coaxial transmission line types vary according to the materials used in their manufacture. This affects their relative electrical length and when used in networks or as jumpers must be considered carefully.

Here are a few examples:

RG-214 double shielded ½” flex	- 66%
RG-8A single shielded ½” flex	- 66%
RG-58 single shielded ¼” flex	- 66%
RG-58 ¼” foam dielectric	- 79%
RG-142B/U TFE® dielectric ¼”	- 70%
Belden 9913 Foam PE, ½”	- 78%

The electrical equivalent of a coaxial transmission line is analogous to an *infinite* number of little coils and capacitors, as depicted in Figure #4, in addition to the electrical resistance of the conductors.

The fifty ohm enigma, or, “Have you got a match?”

The “coils” are the distributed inductance of the conductors and the “capacitors” consists of the distributed capacitance between the inner and outer conductors as modified by the nature of the dielectric materials and the electrical resistance of the conductor materials used. Delay effects due to velocity factor of cable dielectric materials must be understood and accounted for in any cable network design.

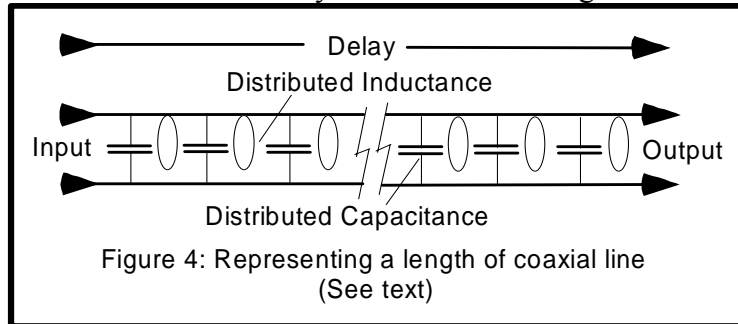

If, for example, you were to replace a 24” long cable made of standard RG-58A cable with one made with RG-142B/U double shielded, silver plated conductor cable it must be physically 4% or almost *a full inch* shorter to exhibit the same effective electrical length. Where precise performance is involved, be aware that the velocity factor of a given cable type can vary somewhat by manufacturer and even by the production run of a given manufacturer.

Loss Due To Thermal Effects

Losses in various coaxial cable types are listed in manufacturer’s catalogs in decibels (dB) of *loss per hundred feet*, or *per meter* in metric measurements. This is often based on measurements made at a low power level, such as 1 milli-watt and usually referred at 10, 100, 1,000 MHz. frequencies and at an ambient temperature of 68° F. (+26° C.).

As applied power and/or ambient temperature is increased, the loss increases due to an effect known as “*I-squared-R loss*,” from the basic formula: $P = I^2 * R$, where P = Power, I = Current Flow and R = Resistance. With a given resistance, when more power is applied more current flow results and losses will increase on a “square law” basis. Suppose that a given manufacturer’s RG58A/U cable is rated at 2 dB of loss per 100 feet at 150 MHz.. You could confirm the actual loss by attaching connectors at each end of a 100 ft. length and measuring this using a calibrated test signal source and a spectrum analyzer displaying decibels of loss directly on the screen or with a wave analyzer set-up. A loss of 2 dB represents a power ratio of 63.1%.

If you should place *identically calibrated* watt-meters at each end of the cable and apply 100 watts of power from a 150 MHz. transmitter, terminating into a 50 Ω load termination you might measure about 63 watts into the load initially. After a few minutes, however, you will find that the power out of the cable has dropped down to perhaps 48 watts which calculates out to be a loss of a bit over 3.2 dB. The cable will soon begin to feel warm to the touch. If you apply transmit power long enough, thermal stability in the cable will be reached and output will stabilize at some even lower level.

This demonstrates the effect of I^2R loss! This cable, if used to feed an antenna, would waste more than half of the transmitter’s power as heat before it arrives at the antenna with 100 watts applied! The *drift* in loss occurs as the inner and outer conductors

The fifty ohm enigma, or, “Have you got a match?”

continue to increase in resistance due to the copper conductors having a *positive temperature coefficient*, and possibly an increased loss factor of the dielectric material when heated. For 100 watts of transmit power you should to use a lower loss, higher power rated cable type. This is particularly true where high operating duty cycles are present in a given system.

In Arizona, for example, temperatures can sink to zero degrees or below during winter periods and reach well over 110° F. in mid summer at high elevation sites. During our hot summer months coaxial lines become preheated by the sun and when power is also applied the resulting I^2R losses can become surprisingly high. The resistance of the conductors changes with temperature variations and the characteristics of the dielectric materials can also change, adding to the loss and modifying the velocity factor of the cable, as well as changing the impedance of the cable. The result of these changes is that the true impedance of any cable can and will change to the point where it isn't 50 Ω as it was under nominal, milder ambient temperatures. Impedance will increase as cable temperature rises and decrease when temperature is lowered.

The *effective impedance* of some 50 Ω cable types has been found to change by as much as 10 Ω where ambient temperature varies over more than 60 degrees and high or continuous transmit duty cycles are present. This, in addition to I^2R loss, is sufficient to result in a noticeable change in communications ranges in addition to the problems resulting from mismatches presented to transmitter P. A. stages and receiver input connectors.

About Antennas

Most communications system antennas fall under one of five categories:

- “Gain” antenna types, either exposed dipole arrays
- Collinear stacked element types in a fiberglass radome,
- Multiple element directional “Yagi” types,
- “Panel” antennas used mostly used at frequencies above 700-800 MHz. and
- “Corner Reflector” and parabolic reflector types.

Most, or all, of these antenna types are vulnerable to detuning effects when significant amounts of moisture, snow or ice clings to them. It is often found that *production run* antennas vary considerably from their manufacturer's stated specifications when subjected to extended power testing. Most types and models appear to perform more or less as expected unless damaged by lightning, wind, water, ice and the like or simply degraded as the result of aging of the materials used in their manufacture.

All antennas have a rather finite use life, most of them having degraded markedly after five years or more of exposure to the elements and continued application of R. F. power. Many antennas have demonstrated considerable characteristic drift under extended application of power *even when new*, probably due to I^2R loss effects. An antenna's power handling capability can be verified by driving it with a very short length of low loss cable and watching for changing reflections from it after extended application of power at expected system levels.

The fifty ohm enigma, or, “Have you got a match?”

You may be assured that *every* antenna has *some* drift problem, and that a great many of them have significantly changed in their true characteristics after a few years of use. Most antenna manufacturers catalog sheets rate the VSWR of their models as “1.5:1 or better” over some stated operating bandwidth. Although this might not seem “too bad” it must be realized that a 1.5:1 VSWR represents a 14 dB return loss and a reflection coefficient of .1995, where almost 20% of applied power will be *reflected*. We find, however, that the match to 50 ohms of most antennas is usually much better than 1.5:1 at various points within its published bandwidth, many showing as low as VSWR of 1.15:1 or better, at their “sweet spots.” Antennas touting extraordinary bandwidth rarely can be shown to exhibit “flat” responses over their specified range when new and are even less flat after six months of in service of in-service usage.

The Effect of Long Coaxial Lines

You can be assured that what you might measure in terms of reflected power at the driven end of a length of antenna feed line will result in a false impression of actual antenna characteristics.

For example, you might measure 100 watts of 150 MHz. transmit power to a 100 ft. transmission line feeding a tower mounted antenna. If you see a reflected power of 10 watts at the transmit end, what might be the actual VSWR of the antenna? Let’s say that the particular line in use is rated at 1 dB of loss per hundred feet at the transmitting frequency involved. The line will lose 20%, or about 20 watts, before reaching the antenna. The reflected power from the antenna will also be reduced by 20% due to line loss. If the antenna has a 1.5:1 VSWR, reflecting 20% of the power applied to it, we find that:

Input power applied to feed line...	100 W.
Power applied to antenna.....	80 W.
Power reflected by antenna.....	16 W.
Radiated signal power by antenna...	<u>64W</u>
Reflected power <i>as measured</i> <i>at the driven end of line</i>	12.8 W.
Error due to losses in line.....	3.2 W.

The line loss causes a false perception of actual antenna match. In this example, the relatively small reflected power loss in the line might be considered to be insignificant but this points up the effect of line loss on the validity of such measurements. At 800 or 900 MHz., where long line lengths might be used line loss can lead to considerable errors in evaluating the condition of an antenna through measuring reflected power.

There can be conditions in which the reflected power is partially “bounced back” up the line if it arrives at the transmitter’s output port in *just the right phase* to add to the incident (desired) signal power. This, however, is unlikely to occur and if it does, is of relatively small consequence. Many technicians tend to accept what they see as reflected power at the transmitter end of a line as a true measure of antenna characteristics. Long feed line lengths tend to “cover up” faulty, damaged or broken antennas.

The fifty ohm enigma, or, “Have you got a match?”

Coaxial Line Segments As “Repeater” Sections and “Stubs.”

If you have a length of line that is an exact electrical *half wavelength* or a true multiple of a half wavelength long at a particular frequency this is often referred to as a “*repeater*” line section, tending to *mirror* (or repeat) the impedance that is “seen” at the input, at the output. To find a half wavelength at some given frequency this simple formula can be used:

$$L \text{ (length, feet)} = 468 / \text{Frequency (MHz.)} \times \text{VF (cable velocity factor, \%)}$$

Example: $\frac{1}{2}$ wavelength of RG214B/U cable at 155 MHz. will be:

$$468 \div 155 * .66 = 2.06 \text{ ft. (24.7 inches)}$$

Bear in mind that in practice, you must account for the *effective* lengths of connectors when developing practical networks of cables, subtracting these lengths from your actual cable measurements as appropriate.

Where an effective half wavelength cable is concerned, the signal at the cable’s output will be translated 180° in phase from the applied signal. Where multiple half wavelengths are present, this also “repeats” at each half wavelength point along the line, these phase reversals bringing the signal back into phase for even half wave and out of phase for odd half wave length multiples of cable.

A shorted length of cable, $\frac{1}{4}$ *wavelength* in effective length of a given impedance acts as a “*shorted stub*,” having a phase translation of 90° and if the “open” end is inserted along a line will appear resonant at the fundamental frequency much as a parallel coil and capacitor tuned circuit will resonate. At the *second harmonic* of the fundamental frequency, however, the stub acts as a trap, exhibiting an impedance of zero Ω at the shorted end. Such a stub is often used to reject second harmonic energy in many system applications, providing 40 dB or more of second harmonic suppression. Shorted stubs, having lengths shorted or longer than $\frac{1}{4}$ effective wavelength are often used to correct impedance mismatches in complex circuit situations.

The phase transposition effect of $\frac{1}{4}$, $\frac{1}{2}$ and $\frac{3}{4}$ wavelength cables are used most effectively in “*Hybrid Ring*” and “*Wilkinson*” type *hybrid coupler* designs for use at UHF and VHF frequencies. Coaxial cables having effective lengths longer or shorter than $\frac{1}{4}$ and $\frac{1}{2}$ wavelengths and their multiples can be used as *impedance transformers*, and provide a means for matching elements of impedance mis-matched system devices together. Cables longer than $\frac{1}{2}$ wavelength exhibit an inductive effect and those shorter than $\frac{1}{2}$ wave become capacitive.

Therefore, the trick in matching mis-matched systems together is to find a cable length that produces equal and opposite inductive or capacitive effects to arrive at a net *resistive* match. The means of accomplishing this are the most important tools that cable network designers have to work with.

The fifty ohm enigma, or, “Have you got a match?”

Complex Impedance Characteristics.

The true, or real, impedance of a radio frequency device, as stated previously, is determined by the result of electrical resistance combined with inductive and capacitive reactances. Where capacitive reactance and inductive reactance are equal, the circuit will become resistive in character. *This can occur only at some particular radio frequency for a given length of cable and having a given velocity factor.*

If two 50 Ω devices, such as the output of an exciter and the input to a P. A. are connected together with a true electrical half wavelength of 50 Ω line, or a multiple thereof, a matched condition will be present and the excitation power will be coupled to the P. A. without reflections. If *one or both* of the connected devices exhibits an inductive or capacitive characteristic *a mismatched condition will exist.*

To explore this a bit more, some basic theory will be revisited. Since radio frequency power is really *high frequency alternating current and voltage* compared with, say, our 60 Hz. domestic A. C. power, the implications of impedance are explained by basic A. C. theory. To best understand this, we first define a “*sine wave.*”

More Radio Frequency Basics

“Alternating current” generators work by virtue of causing an electrical conductor to “cut” through a fixed magnetic field. If a single loop wire conductor is rotated between the poles of a fixed magnet, a resulting voltage wave form will be generated. The amplitude of the voltage will be zero when the loop is at right angles to the magnetic flux path, and as the loop is rotated through 90° the voltage will be at a maximum as the magnetic lines of force are “cut” at the highest rate. In actual generators, forms of “slip rings” are used to couple the resulting voltage wave form out of the device.

As rotation continues to 180° the voltage amplitude will return to zero, then toward 270° the voltage will change polarity and reach maximum, then return again to zero when 360° of rotation has occurred.

The formula below describes the resulting electromotive force:

$$e = E_m \sin \theta$$

Where:

e = instantaneous value of electromotive force
(voltage) at any angle θ ,

E_m = maximum value of electromotive force, and

θ = angular position of the rotating loop, degrees

Since the amplitude of the developed voltage follows the algebraic *sine* function of angular displacement relative to the amount of rotation, we use the term “*sine wave.*” Whether having a frequency of 60 Hz. per second or 60 GHz. per second, alternating current sine wave energy relates to impedance in the same manner. Radio Frequencies are generally considered to be those frequencies that will traverse space as *magnetic field wave fronts*. These frequencies range from about 50 KHz. through perhaps 500 GHz. in current usage The *purest* form of this energy is the sine wave. Complex wave forms

The fifty ohm enigma, or, “Have you got a match?”

exist, also, either as developed or as the result of distortions. Radar pulse power and most digital bits, independent of means of encryption start out as true square waves but usually become deformed in the process of transmission and reception so that they may become decoded (demodulated.)

Phase Relationships

If a *purely resistive* load is placed across the output terminals of an A. C. generator the current in the loop will follow the same pattern and will be *in phase with the voltage*. If the load is purely *inductive* in character the current will *lead* the voltage by 90° and if the load is purely *capacitive* the current will *lag* the voltage by 90° . Where complex impedances are present the actual phase relationships will be the result of inductive, capacitive and resistive characteristics of the load.

These relationships hold true from A. C. power frequencies through the entire usable radio frequency spectrum. Since there are combinations of resistance, capacitance and inductance in all practical circuits. We must compensate for them when connecting devices together if an impedance match is to be enjoyed.

The character of all connecting devices, the cables used between the devices must and the devices themselves must fully consider these matters of impedance and treat them as a system.

Signal Radiation From And Between Transmission Lines

As shown in Figure 2, if the ratio between the inner and outer conductors is adjusted to result in a $50\ \Omega$ characteristic impedance and the dielectric material is dry air, the ratio will be found to be about 4.3:1. Where other dielectric materials are employed this ratio becomes smaller due to the higher effective velocity factor of the material used. If the source impedance driving a $50\ \Omega$ line and the load impedance at the delivery end of the line is also $50\ \Omega$ the loss of power in the line will result only from I^2R loss *plus* loss provided by the dielectric material.

A coaxial transmission line, consisting of two concentric conductors separated by a dielectric medium is, within itself, a *self contained system*. An electrical field *and* a magnetic flux field exist between these conductors. These fields decay rapidly outside of and away from the line itself when the line and the devices to which it is connected exhibit *identical* impedances and signal radiation from the line's outer conductor will then be at a minimum.

Be aware, however, that when mis-matches are present, “standing waves” can appear along the outer conductor that will radiate signal power and can result in *unwanted coupling* to or with other nearby cables. This is the main reason to avoid “bundling” receiving lines with transmitting lines along tower legs or in other cable routings, since it is almost never the case that all cables enjoy “perfect” matches with the associated equipment in a typical or actual system situation. We have, all too often found receiver and transmitter cables run parallel in cable trays that are common at large scale communications sites. Many intermodulation and receiver desensitization problems have been solved simply through cable re-routing.

The fifty ohm enigma, or, “Have you got a match?”

Transmission Lines As Impedance Transformers and Matching Devices

As previously explained, phase changes occur along lengths of transmission line as determined by line length and frequency. By properly selecting line lengths, we can then use them to effect a *conjunctive match* between otherwise mis-matched devices. A convenient method of phase comparison is through *vector analysis*. It is most valuable for the reader to consider reviewing this mathematically sourced means of angular phase displacement calculations. Texts that are helpful in learning principles and use of vector analysis are available in most libraries in electrical engineering departments.

An academic approach to this suggests making an analysis of each element of a combination of devices using complex measurement techniques, then calculating and constructing a cable of a length that is just right to translate the correct phase angles to effect a conjunctive match between the devices in question. This may be well and good, but when something is overheating or mal-functioning in the field it is rarely reasonable to go through the kinds of measurements necessary to secure the information needed to accurately construct a correcting line length. There is, however, a simple and practical solution for many of these situations:

A Line Matcher

This little device is really a “PI” network built in a convenient one inch square container with a male Type N connector at one end and a Female Type N connector at the other end. It has two adjustable capacitors that permit a wide range of impedance translation through the device within traditional land mobile operating bands.

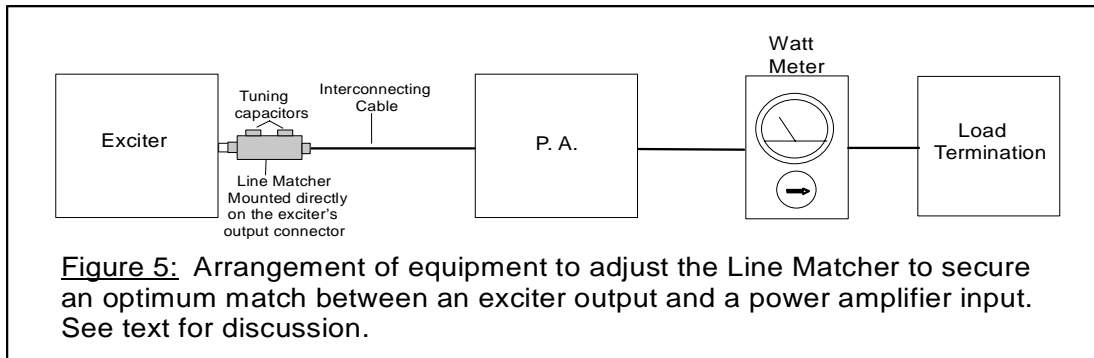

Suppose that you are not sure that an exciter output matches the input impedance of a P. A. input. You suspect that the cable is the wrong length, but you don't know what the right length might be! In 90% or more of such cases you can correct the situation by using a Line Matcher. The set up for the application of this little device is as shown in Figure 5.

Note that the line matcher is placed right at the exciter's output. Key up the exciter and through alternate adjustments of the two capacitors of the line matcher find the highest output from the P. A. If the P. A. is rated at, say, 100 watts output level reduce the exciter's output level as you tune, each time re-peaking the matcher for maximum P. A. output. This procedure actually *finds* the exciter and P. A. input

The fifty ohm enigma, or, “Have you got a match?”

impedances along with cable length effect and provides an optimum match, the point at which highest efficiency of power transfer exists. *Do not* try this by inserting the wattmeter between the exciter and the P. A. unless you intend to leave the meter and its jumper cables in place, for obvious reasons.

Summary

Hopefully, the reader has gleaned something of value from this write-up. It was prompted by the fact that over many, many years of system design experience along with the development of a comprehensive line of system products, many of the products of EMR Corporation and other filter device, radio equipment and accessory power amplifier manufacturers have suffered field failures that should never have occurred had reasonable attention been applied to details of impedance matching during the field installation process.

We have heard a litany of comments such as “...it *should have* taken that extra power if it was designed right!” – or - “Why can’t *you guys* design an amplifier that will adjust itself to any power level that I want it to work at!” The answer is that we can do that but the costs to manufacture would escalate due to the need for using larger, more expensive components and the inclusion of numerous sensing and protection circuits in the designs to render them “bullet proof.” (Many such components are available as options or add-on system elements, contact us for info.) Such niceties, however, can increase the market price of an amplifier, for example, by as much as 75%.

System users have suffered unnecessary down time, lost revenue and extraordinary operating costs because of mis-application of perfectly good products and all manufacturers have suffered costly and unnecessary warranty adjustment costs arising from product mis-applications.

I trust that the discussions offered in this write-up will serve as a refresher, to renew the wireless system engineer or technician’s concern for the matter of overall system impedance matching.

The fifty ohm enigma, or, “Have you got a match?”